



FLUID TECHNOLOGY SOLUTIONS

Specialist in Flood Defence, Sewage Surge, Flood Management
Warning Alert System

Office and Mobile:- + 44 7957 232331

AQUALOGIX activated carbon and UF filter
Drinking Water Plant from Ashton Industrial

R S Garrow Ltd

Business & Product Development

Office : +44 141 956 2732

Mobile: +44 7711 498649

Web : <http://www.rsgarrow.co.uk>

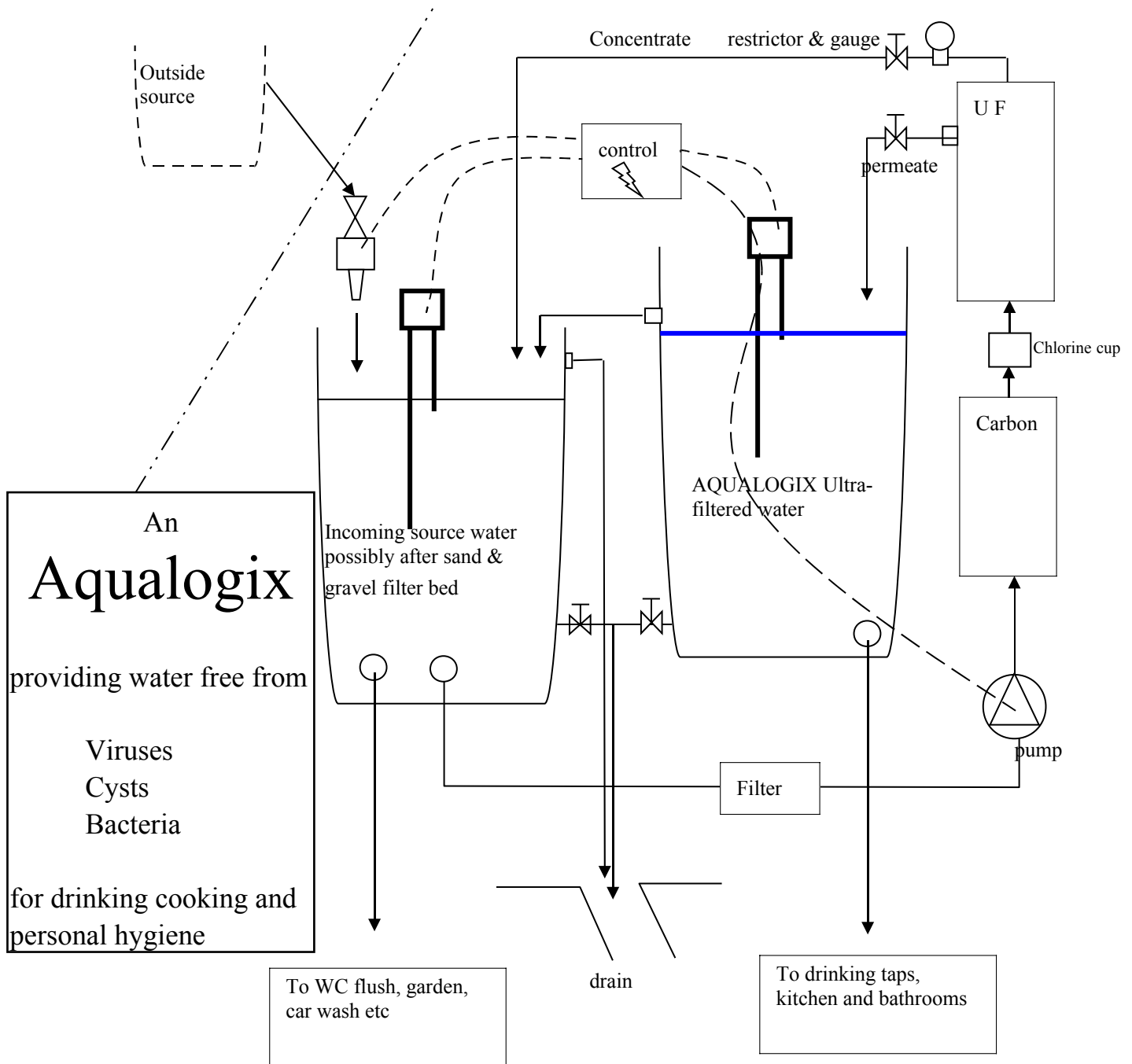

Source water from an external main or collection tank is allowed into tank 1 via an automatic valve, which is triggered by a water level probe with min/max settings. The inlet is positioned above the tank rim to prevent siphoning.

A standard household outlet connects this water to selected points where Ultra Filtered water is unnecessary. An outlet from tank 2 feeds all drinking water, washing and cooking points. A probe signals when water level drops, starting the pump which pulls water from tank 1, through a particle filter, and pushes it through the AQUALOGIX activated carbon and UF filter. Permeate is collected in tank 2 until maximum level is replenished before the pump stops. Concentrate is returned to tank 1, via a pressure gauge and restrictor to provide the necessary back-pressure for the AQUALOGIX.

For occasional disinfecting, a chlorine cup where tablets can be inserted, is provided.

Eventual excess from tank 2 overflows back to tank 1. Excess in tank 1 flows to drain.

To combat stagnation the controller is programmed to run the pump for a minimum duration of xxxx every xxxx hours. This timer re-sets each time the pump is triggered



Evaluation EB 05331 Multimedia UF

The product is a small, compact water treatment system which has been conceived specially for the decentralised treatment in small water works or for personal use. The system (see drawing) is using two different technologies: adsorption and ultrafiltration. With through-flow outputs of approx. 220 l per day the treatment is designed in such a way that now even the smallest water supply units can have a good water quality. The unit treats the water with ultrafiltration membranes. This plastic membrane has pores with an area of 0,01 μm , these pores are so fine that neither bacteria nor viruses can pass the membrane. The water which leaves the unit is therefore absolutely germ free.

The unit needs a regular sanitisation as described in the manual. Chemical cleaning and disinfection using hydrogenperoxide is carried out several times to be on the safe side. The regular cleaning is an important part of the maintenance. The use of Hydrogen peroxide disinfection agent is easily degradable and does not cause any damage in the bordering stream. An integrity test is carried out during maintenance work. This would reveal any possible leaks in the membrane.

The membrane is tested and proved. See NSF certificate OS021-01

The unit was tested in a study on the removal of pharmaceutical residues, heavy metals, steroid hormones and polar pesticides from fortified water samples applying the test unit.

Several polar pesticides frequently used in Agriculture and several pharmaceutically active compounds originated from municipal sewage effluents have recently been recognized as potential ground water contaminants, In this test the reduction and removal efficiency for the different chemicals is documented. The study concerning the removal efficiency was carried out in two parallel experiments. The water was spiked at individual concentrations of 0,1 or 1,0 $\mu\text{g/l}$ per compound.

This level was selected with regard to information of drugs residues in typical water coming from the surface.





Water Services from **R S Garrow Ltd**

FLUID TECHNOLOGY SOLUTIONS

The laboratory experiments and the additional experiments under practical conditions show that all of the investigated compounds were removed in a successful rate. During the complete test time (1 week and about 200 l per day) all of the investigated compounds were efficiently removed at healthy concentrations. In almost all of the effluents from the filter none of the fortified contaminants could be detected. Infrequently, a few of the spiked contaminants were detected, but only at a trace level concentration close to the limit of detection (below 1 ng/l). Thus as compiled in the following table, the removal rates of the individual analytes calculated from the spiked concentration and the detection limits of the analytical procedures were between 99 and 99,9 %

Important: the test unit must follow the manual and regular maintenance

Analyte	Removal efficiency	Remarks
carbamazepine	> 99,9 %	polar drugs
clofibric acid	> 99,9 %	
diclofenac	99,1- 99,9 %	
ibuprofen	> 99,9 %	
ketoprofen	> 99,9 %	
propyphenazone	> 99,9 %	
17 β -estradiol	> 99,9 %	steroid hormones
ethinyl estradiol	> 99,9 %	
bentazone	> 99,9 %	polar pesticide residues
2,4-D	> 99,9 %	
dichlorprop	> 99,9 %	
MCPA	> 99,9 %	
mecoprop	> 99,9 %	
p,p'-DDA	99-99,5 %	

Result of the test with fortified water with copper.

No.	flow l in total	Copper mg/l	product water Copper mg/l	% reduction
1	100	3,6	0,04	98,9
2	200	3,4	0,04	98,8
3	300	4,4	0,04	99,1
4	350	4,5	0,05	98,9
5	400	4,5	0,04	99,1
6	470	4,3	0,04	99,1
7	520	4,1	0,04	99,0
8	620	4,2	0,04	99,1



FLUID TECHNOLOGY SOLUTIONS

Water Services from R S Garrow Ltd

The test gives also good results: the reduction rate is about 90 % over the total test time. It is very important to know that the filter will exhaust over the time. It was not part of this test to find out when this will happen. The exhaustion is a function of the feed concentration.

Reduction of microbiological contaminations.

The water passing the unit was spiked. The product water was evaluated.

day	E-coli (CFU/ml)	<u>Enterococcus</u> <u>faecalis</u> (CFU/ml)	after filter E-coli (CFU/ml)	after filter E-faecalis (CFU/ml)
1	5,13 E +05	2,47 E +05	0,00 E +00	0,00 E +00
2	1,44 E +06	1,17 E +05	0,00 E +00	0,00 E +00
3	1,11 E +07	1,79 E +05	0,00 E +00	0,00 E +00
4	2,34 E +05	3,77 E +05	0,00 E +00	0,00 E +00
5	1,46 E +06	4,56 E +05	0,00 E +00	0,00 E +00
6	1,08 E +05	5,23 E +05	0,00 E +00	0,00 E +00
7	1,95 E +05	1,30 E +05	0,00 E +00	0,00 E +00
8	9,63 E +05	2,64 E +05	0,00 E +00	0,00 E +00
9	8,45 E +06	3,17 E +05	0,00 E +00	0,00 E +00
10	6,78 E +06	6,5 E +05	0,00 E +00	0,00 E +00
11	7,23 E +05	2,8 E +05	0,00 E +00	0,00 E +00
12	4,12 E +06	3,63 E +05	0,00 E +00	0,00 E +00

The test shows that the germs will not pass the membrane



FLUID TECHNOLOGY SOLUTIONS

Water Services from R S Garrow Ltd

Summary:

The filter test result show that the designed technology will work. The test results evaluate the expected results.

The unit will exhaust during the use. The user of the system therefore needs a clear manual. The user also must sanitise the system regularly. He has to make a habit of this.

Dr. Herbert Bendlin

Signed and stamped original
available for viewing on request

Attachments: flow chart EB050331
Certificate NSF
Certificate TÜV
Certificate TZW

Original attachments
available for viewing on request

Sa/s

Aqualogix flow chart

EB 05331

Updated 3/10/07

ashton
Industrial

engineering for glass

www.ashton-industrial.com

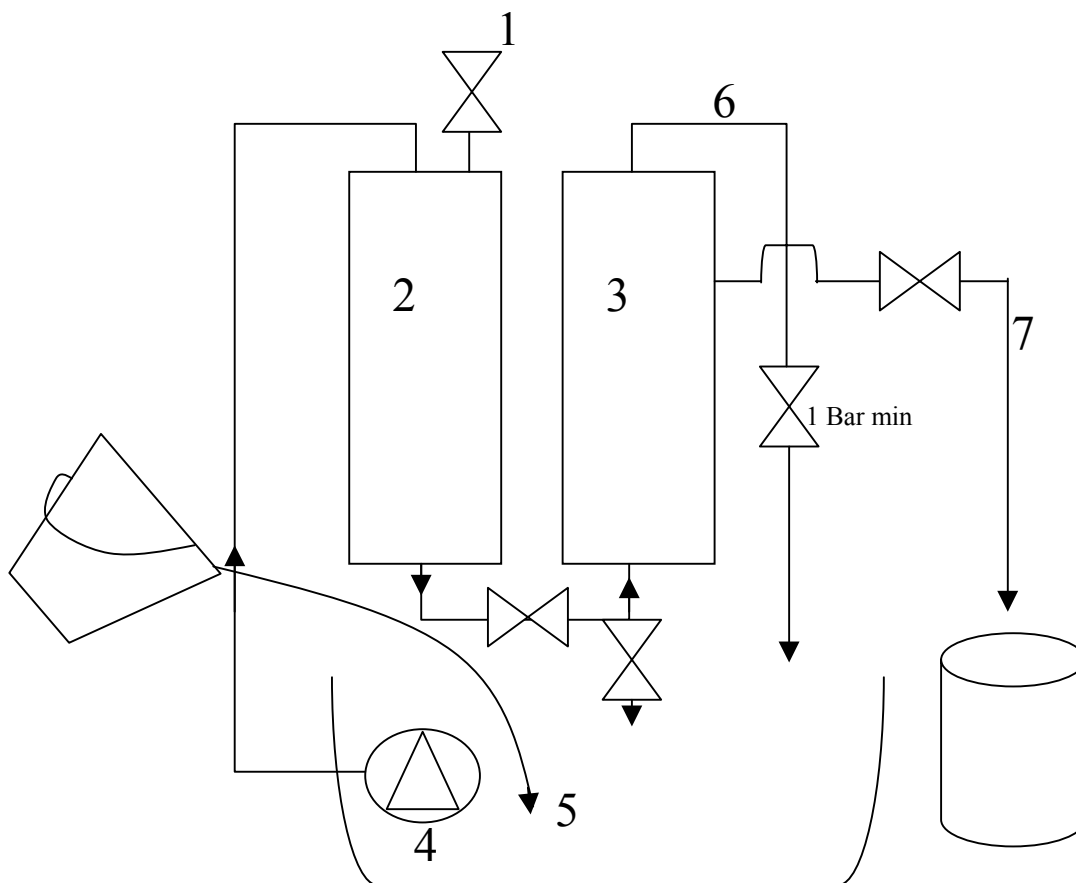

1. Deaeration
2. Multimedia filter e.g. silvered carbon plus other elements V= 5 litres H=60cm
3. UF membrane capillary filter
4. Pump
5. Tank to receive source water
6. Return concentrate
7. Permeate (pure water)



FLUID TECHNOLOGY SOLUTIONS